

Operator's Handbook

Monarch® Sierra Sport4™
9493™ Printer

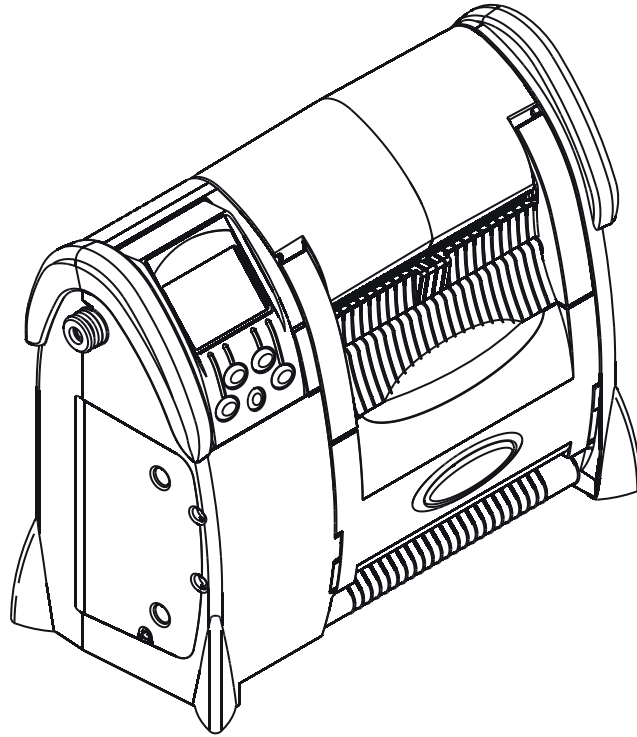

Each product and program carries a respective written warranty, the only warranty on which the customer can rely. Avery Dennison reserves the right to make changes in the product, the programs, and their availability at any time and without notice. Although Avery Dennison has made every effort to provide complete and accurate information in this manual, Avery Dennison shall not be liable for any omissions or inaccuracies. Any update will be incorporated in a later edition of this manual.

© 2008 Avery Dennison Corporation. All rights reserved. No part of this publication may be reproduced, transmitted, stored in a retrieval system, or translated into any language in any form by any means, without the prior written permission of Avery Dennison Corporation.

WARNING

This equipment has been tested and found to comply with the limits for a Class B digital device, pursuant to Part 15 of the FCC Rules. These limits are designed to provide reasonable protection against harmful interference when the equipment is operated in a commercial environment. This equipment generates, uses, and can radiate radio frequency energy and, if not installed and used in accordance with the instruction manual, may cause harmful interference to radio communications. Operation of this equipment in a residential area is likely to cause harmful interference in which case the user will be required to correct the interference at his own expense.

RF Operation is subject to the following two conditions: (1) this device may not cause interference, and (2) this device must accept any interference including interference that may cause undesired operation of the device.

CANADIAN D.O.C. WARNING

This digital apparatus does not exceed the Class B limits for radio noise emissions from digital apparatus set out in the Radio Interference Regulations of the Canadian Department of Communications.

Le présent appareil numérique n'émet pas de bruits radioélectriques dépassant les limites applicables aux appareils numériques de la classe B prescrites dans le Règlement sur le brouillage radioélectrique édicté par le ministère des Communications du Canada.

Trademarks

Monarch®, MPCL, Sierra Sport, 9493, and 9496 are trademarks of Avery Dennison Retail Information Services, LLC.

Avery Dennison® is a trademarks of Avery Dennison Corporation.

Bluetooth® is a trademarks of Bluetooth SIG, Inc.



TABLE OF CONTENTS

Getting Started	1-1
Using this Manual	1-1
Audience	1-1
Printer Utilities	1-1
Unpacking the Printer	1-1
About the Printer's Power	1-2
Installing & Removing the Battery	1-2
Battery and Safety Information	1-3
Connecting the Communications Cables	1-4
Using the Display and Buttons	1-4
Loading Ribbon & Supplies	2-1
Opening & Closing the Printer	2-2
Loading a Ribbon Cassette	2-3
Loading a Ribbon	2-3
Loading Supplies.....	2-5
Loading for non-peel mode:.....	2-5
Loading for peel mode	2-5
Loading for fan-fold.....	2-6
Printing	2-8
Tearing the Supplies	2-8
Care & Maintenance	3-1
Clearing Label Jams	3-1
Cleaning.....	3-1
Troubleshooting	4-1
Common Errors	4-1
Calling Technical Support	4-2
Specifications	A-1
Printer Specifications	A-1
Supply Specifications	A-2
Accessories	B-1
Battery Charger/AC Power Adapter	B-1
Carrying Accessories	B-1
Printer Options	C-1
Bluetooth®	C-1

GETTING STARTED

The Monarch® Sierra Sport4™ 9493™ printer is a portable thermal direct and thermal transfer printer that prints on tags, labels, or receipt paper.

Before using the printer, review the safety information in the *Regulatory Compliance* document provided with your printer.

Information in this document supercedes information in previous versions. Check our Web site for the latest documentation and release information.

Using this Manual

Following is a summary of the contents of this manual:

	Chapter	Contents
1	Getting Started	Installing the battery, connecting the cables, and using the display.
2	Loading Ribbon & Supplies	Loading the ribbon cassette and supplies.
3	Care & Maintenance	Clearing supply jams and cleaning the printer.
4	Troubleshooting	Common problems and their solutions.
A	Specifications	Printer and supply specifications.
B	Accessories	List of accessories and part numbers.
C	Printer Options	List of available options.

Audience

This manual is for the person who prints tags, labels, or receipts.

A *Packet Reference* manual and *System Administrator's Guide* are available on our Web site.

Printer Utilities

The Monarch® MPCL™ Toolbox utilities (version 1.13 and higher) are also available on our Web site and are free to download. This group of development utilities helps you configure the printer, customize fonts, and download files.

Unpacking the Printer

After you unpack the printer, you may have the following (depending on your order). If any items are missing, contact us at the number listed on the back of this manual for replacement items.

- ◆ a 9493 printer
- ◆ one or more batteries
- ◆ a battery charger / AC power adapter
- ◆ a shoulder or hand strap
- ◆ one or more communications cables
- ◆ a fan-fold core (for printing fan-fold supplies)
- ◆ a *Quick Reference*

Note: Look through all of the packaging material for items. Keep all packaging material in case you need to move or return the printer.

About the Printer's Power

There are two ways to power the printer:

- ◆ Using a battery. See "Installing and Removing the Battery" for more information.
- ◆ Using the AC power adapter. Refer to the 9496™ *Operating Instructions* included with the charger/adaptor for more information.

Installing & Removing the Battery

You *must* charge the battery before using it for the first time.

To install the battery:

1. Review the safety information in the *Regulatory Compliance* document included with your printer.
2. Turn off the printer when you change batteries.
3. Lay the printer down so the back of the printer faces up.
4. Remove the plastic from a new battery.
5. Slide the battery into the battery well in the bottom of the printer until it latches into place.

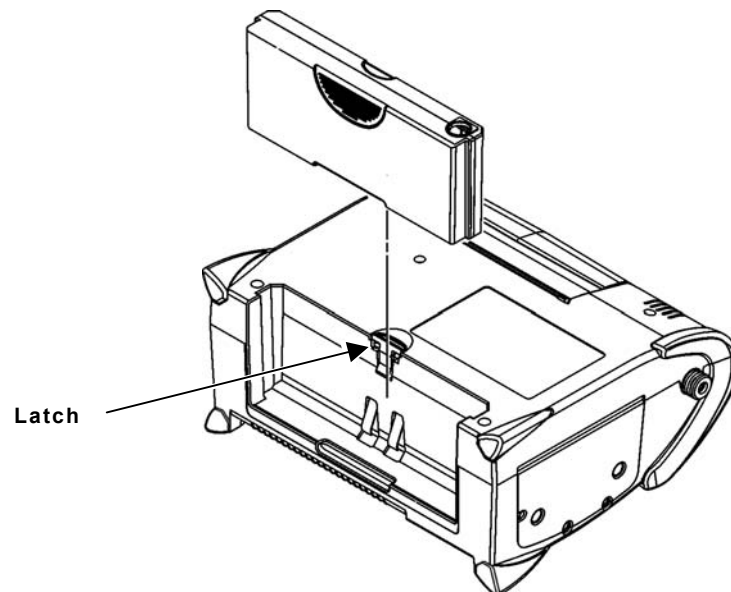

6. Set the printer upright.
7. Turn on the printer by pressing . The display flashes printer version information and battery charging status, then you see



To remove the battery:

1. Turn off the printer.
2. Lay the printer down so the back of the printer faces up.
3. Press the latch down with your thumb and slide the battery out of the battery well.

Battery and Safety Information

- ◆ You must charge a battery before using it. For optimal battery life, charge the battery *within three months of receipt*.

WARNING: Use only the Monarch® 9496™ charger/adaptor designed for Lithium-ion batteries when charging. The battery might explode if used with a different charger. Refer to the *Operating Instructions* provided with the charger/adaptor for more information.

- ◆ The optimal battery storage temperature is -4°F - 104°F (-20°C - 40°C). For more information about storage temperatures, see Appendix A, "Specifications." The battery may lose its charge capacity permanently if stored at temperatures less than -4°F (-20°C) or greater than 104°F (40°C). For longest life, the battery should be stored in a cool, dry place.
- ◆ Prolonged storage or operation of a fully-charged battery above 104°F (40°C) may cause a permanent battery capacity loss of up to 10%.
- ◆ The recommended temperature for charging is 32°F - 104°F (0°C - 40°C)
- ◆ Charging time is approximately 1 to 3 hours.
- ◆ Recycling Information - Do not throw in trash. Recycle to your local regulations. The Rechargeable Battery Recycling Corporation (RBRC®) is a non-profit organization created to promote recycling of rechargeable batteries. For more information about how to recycle batteries in your area, visit www.rbrc.org. Batteries can also be returned postage-paid to: ERC; 200 Monarch Lane Door #39; Miamisburg, OH 45342.

Caution: **Do not** disassemble, short-circuit, heat above 122°F (50°C), or incinerate the battery. It may explode.

- ◆ The battery should be charged immediately for either long-term storage or after the battery has been exhausted from a printing session. Frequent charging prolongs battery life and has no negative effects, such as memory loss.
- ◆ **Do not** let the battery get wet or come into contact with metal objects.
- ◆ **Do not** use a battery with a cracked case.
- ◆ It is normal for battery capacity to decrease up to 20% over the first 400 - 600 cycles of use.
- ◆ The printer uses battery power even when the printer is not printing. Remove the printer's battery when the printer is not in use for a week or longer.
- ◆ Many factors affect your battery's performance, including the quantity of labels printed, intervals of batches printed, percentage of black per label, and power management.

Connecting the Communications Cables

You can communicate serially (9-pin) or through USB (version 2.0).

For best results, use only Monarch® cables. See Appendix B, "Accessories" for part number information.

To connect serial cables:

1. Open the hinged cable door on the side of the printer by loosening the two screws with a Phillips screwdriver.
2. Plug the DB9 connector into the DB9 port.
3. Place the cable into one of the cable cavities.
4. Close the cable door and tighten the screws.

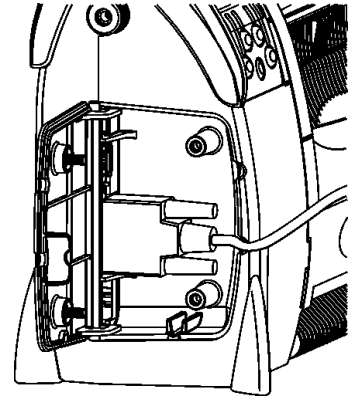

To connect USB cables:

1. Open the hinged cable door on the side of the printer by loosening the two screws with a Phillips screwdriver.
2. Plug the USB type A connector into the USB type A port or plug the USB mini-B connector into the mini USB port.
3. Place the cable around the top screw post and into one of the cable cavities as shown.
4. Close the cable door and tighten the screws.

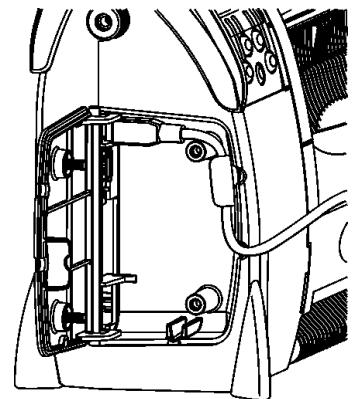

USB mini-B cable shown

Using the Display and Buttons

- ① Turns the printer **on** and **off**.
- ⓪ Four navigation buttons for selecting options on the display.

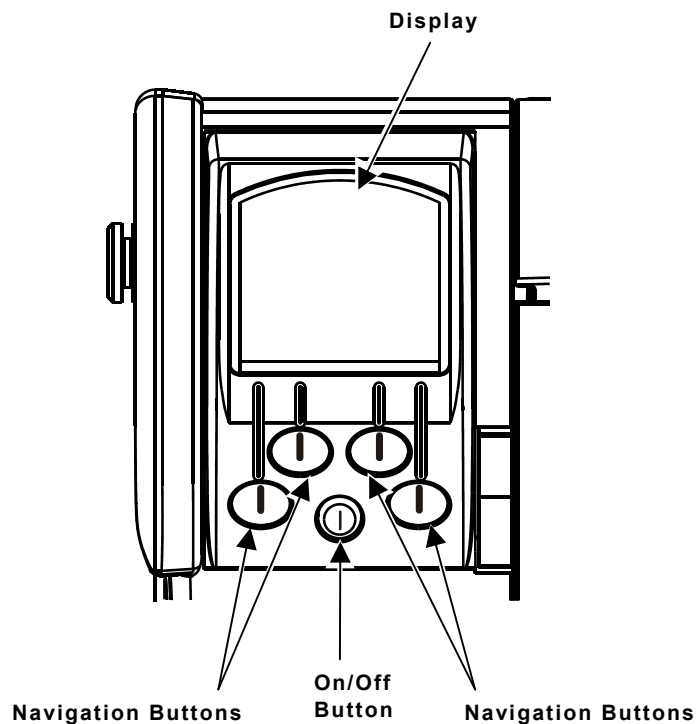



LOADING RIBBON & SUPPLIES

2

This chapter describes how to load supply for

- ◆ non-peel mode (prints on continuous strip of supply).
- ◆ peel mode (prints and separates the label from the liner).
- ◆ fan-fold.

Supply loading tips:

- ◆ Whenever you open and close the printer, press  under  to advance the supply under the printhead.
- ◆ The printer may be on or off when loading supplies.

Opening & Closing the Printer

Before loading ribbon or supplies, you must open the printer. Close the printer before printing.

To open the printer:

1. Insert your fingers into the indent beneath the supply door latch and lift.
2. Make sure the latch arms are free of the ribbon cassette.

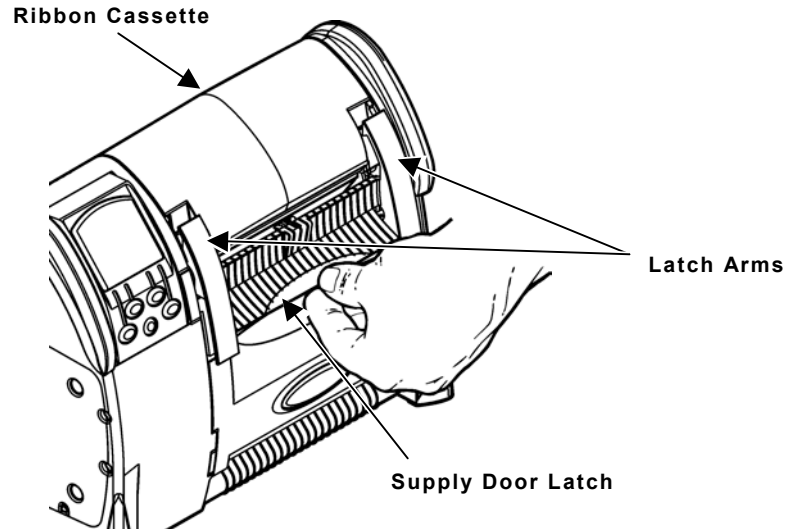

3. Tip the ribbon cassette back, if necessary, to lower the supply door.

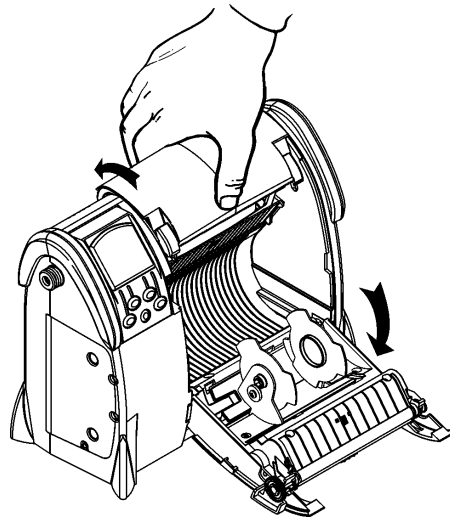

4. Load ribbon or supplies. See “Loading a Ribbon Cassette” or “Loading Supplies” for more information.

To close the printer:

5. Tilt the ribbon cassette back, if necessary, and raise the supply door.
Tilt the ribbon cassette back down.
6. Lift the supply door latch. Make sure the latch arms catch each side of the ribbon cassette.
7. Push the supply door latch down into place.

Loading a Ribbon Cassette

Use a ribbon to print on thermal transfer supplies.

1. Open the printer. See “Opening & Closing the Printer” for more information.
2. Tip the ribbon cassette back, if necessary, and pull it towards you until it slides out of the printer.

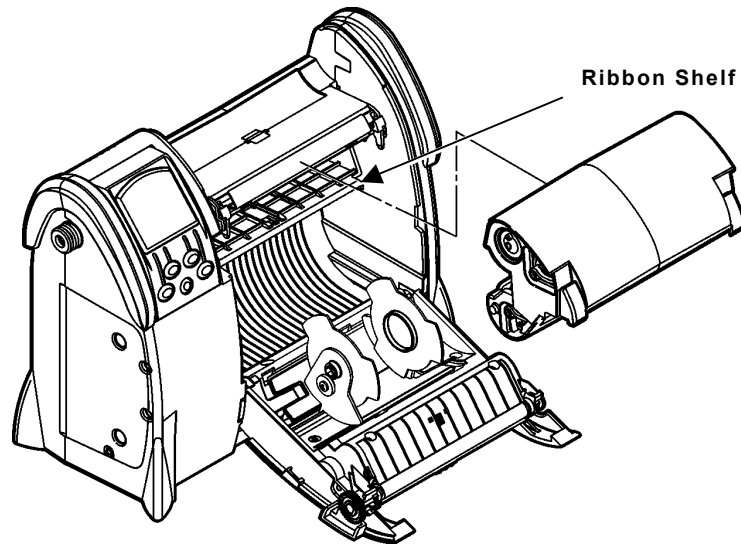

3. Slide a new ribbon cassette with a loaded ribbon into the printer.
See “Loading a Ribbon” for more information about loading a ribbon into the ribbon cassette.

Note: The ribbon shelf raises and lowers automatically when you are removing and loading a ribbon cassette.

4. Close the printer. See “Opening & Closing the Printer” for more information.

Loading a Ribbon

1. Remove the ribbon cassette from the printer. See “Loading a Ribbon Cassette” for more information.
2. Rotate the two latches on side “A” of the cassette until they snap into the unlocked (◀||▶) position.

Note: The latches rotate in opposite directions.

3. Turn the ribbon cassette so side “A” faces downward.
4. Lift side “B” of the cassette (without the latches) off and set it aside.
5. Remove the used ribbon and take-up reel.

6. Remove the clear wrap from a new ribbon and tear it at the perforation.

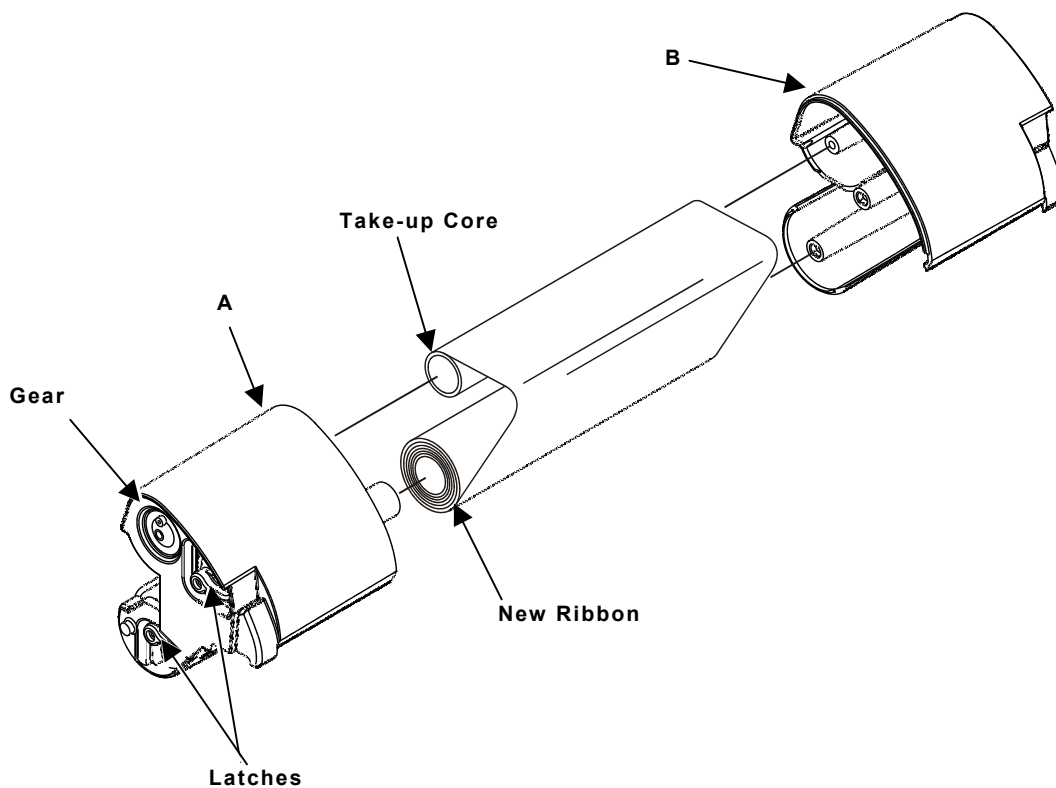

7. Make sure the preprinted side of the ribbon faces out. Slide the ribbon reel onto the long spool with the foam washer and the take-up reel onto the short spool. Thread the ribbon around the ribbon guide. Turn the ribbon roll slightly to take up some of the excess slack, if necessary.

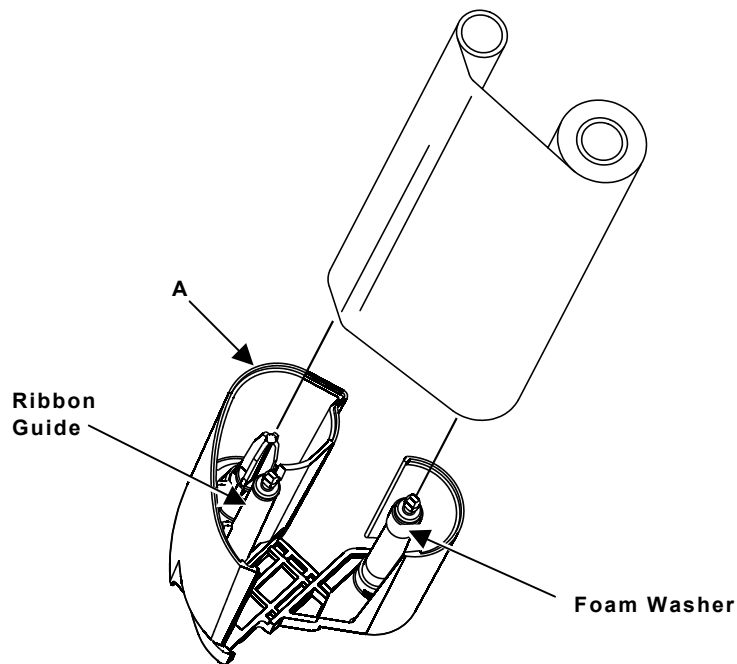

Do not wind the ribbon too tightly. **Do not** touch the ribbon with your fingers. **Do not** wrinkle or twist the ribbon.

Note: If you are using a 2-inch or 3-inch ribbon, push the core of the ribbon roll onto the spool of the cassette but **do not** force it or you may damage the foam washer. **Do not** touch the ribbon with your fingers!

8. Carefully replace the other half of the ribbon cassette so they fit together completely. **Do not** wrinkle or crush the ribbon!
9. Rotate the latches until they snap into the locked (→|←) position. They may have moved during ribbon loading.
10. Turn the gear counterclockwise with your fingers until you see the black part of the ribbon.

The ribbon cassette is ready to use in the printer. See “Loading a Ribbon Cassette” for more information.

Loading Supplies

Non-peel mode prints supplies in a continuous strip. Use these instructions to load labels, tags, and receipt paper. The printer’s default supply setting is black mark.

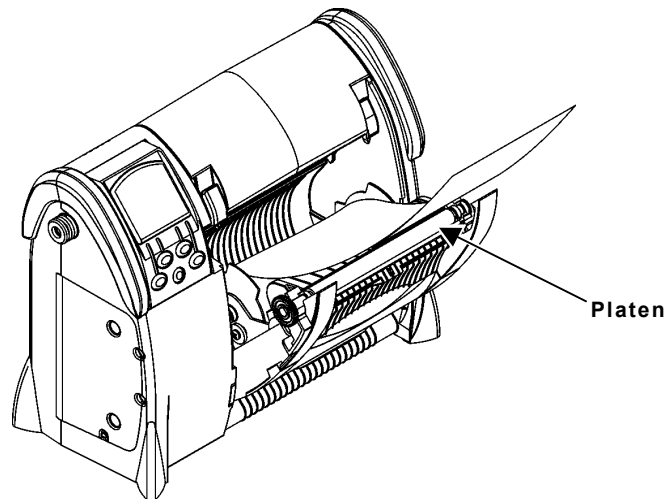

Loading for non-peel mode:

1. Open the printer. See “Opening & Closing the Printer” for more information.
2. Remove the tape from a new roll of supply.
3. Push apart the supply holder tabs to widen the supply holder. Insert a roll of supplies so it unwinds from the top as shown.



4. Pull out the supply so that a few inches extend past the front of the printer. Center the supply across the platen roller.
5. Close the printer. See “Opening & Closing the Printer” for more information.

Note: Make sure the printing side of the supply faces up after you close the printer.

6. Turn on the printer if it is not already on.
7. Press  under  to advance the supply under the printhead. If you receive a supply error, see Chapter 4, “Troubleshooting.”



Loading for peel mode

Peel mode removes the label from the liner as it prints. It is only for labels. This mode allows you to apply the label immediately. When the printer is in on-demand mode, the next label prints automatically when the previous one is removed.

1. Open the printer. See “Opening & Closing the Printer” for more information.
2. Remove the tape from a new roll of supply.
3. Push the supply holder tabs apart to widen the supply holders. Insert a roll of supplies so it unwinds from the top.

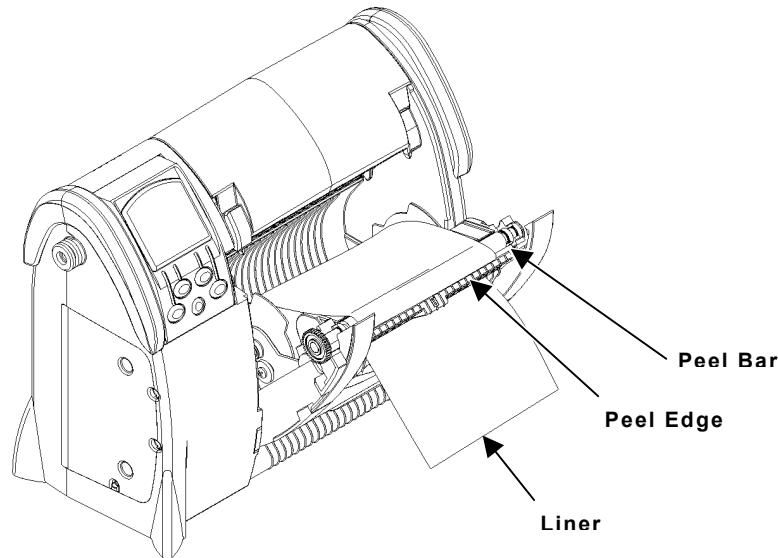
4. Pull out the supply so that a few inches extend past the front of the printer. Center the supply across the platen roller.
5. Raise the supply door back to the upright position but do not close the printer.
6. Remove a couple of labels from the liner. Feed the liner over the platen roller, over the peel bar, and **under the peel edge** as shown. Center the supply under the peel edge.



7. Close the printer completely. See "Opening & Closing the Printer" for more information.
8. Lightly tug on the liner to remove the slack.
9. Turn on the printer if it is not already on.
10. Press  under  once or twice to advance the labels under the printhead. If you receive a supply error, see Chapter 4, "Troubleshooting."

The label separates from the liner.

Loading for fan-fold

Use these instructions for fan-fold supplies only.



1. Open the printer. See "Opening & Closing the Printer" for more information.
2. Adjust the 4.8-inch (122 mm) core to the width of your fan-fold supplies by pushing or pulling the supply guides on each side of the core. The guides move in 0.03-inch (0.8 mm) increments.

Note: Make sure the guides are straight after you adjust them.

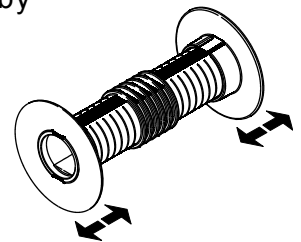
3. Insert the core between the supply holder tabs to open them to their widest position.

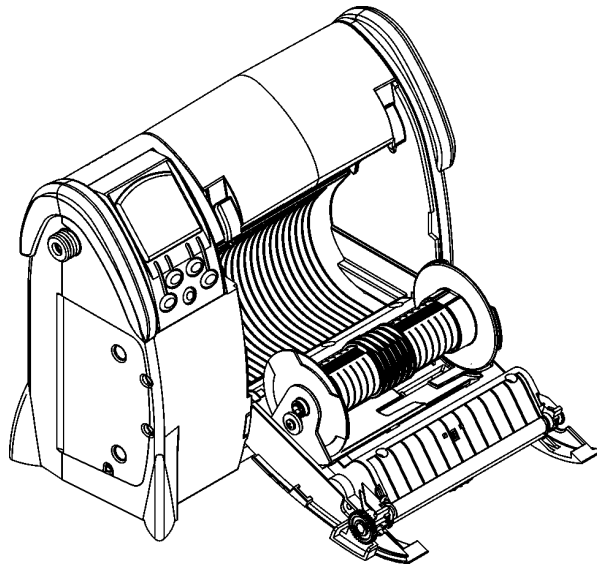



4. Position a stack of fan-fold supplies so they feed easily into the front of the printer.
5. Feed the fan-fold supply into the supply slot under the supply door and between the supply guides on the core so that a few inches extend past the front of the printer. Center the supply across the platen roller.
6. Close the printer. See "Opening & Closing the Printer" for more information. Make sure the printing side of the supply faces up after you close the printer.
7. Turn on the printer if it is not already on.
8. Press  under  once or twice to advance the supply under the printhead. If you receive a supply error, see Chapter 4, "Troubleshooting."

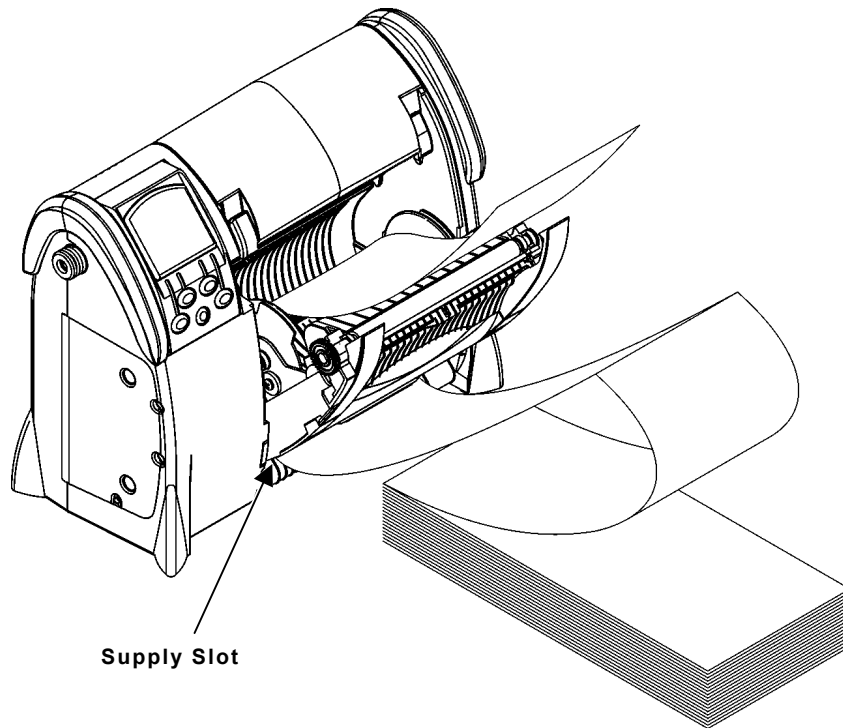

Printing

The host sends online packets containing print jobs to the printer.

1. Turn on the printer. You see



2. Download a format and a batch.

For information on creating packets and downloading print jobs, refer to the *Packet Reference* manual available on our Web site.

The printer prints either a strip of supplies or one at a time (on-demand mode).

3. Remove the printed supplies.

Tearing the Supplies

Tear the supply from the right or left using the tear edge as a guide.

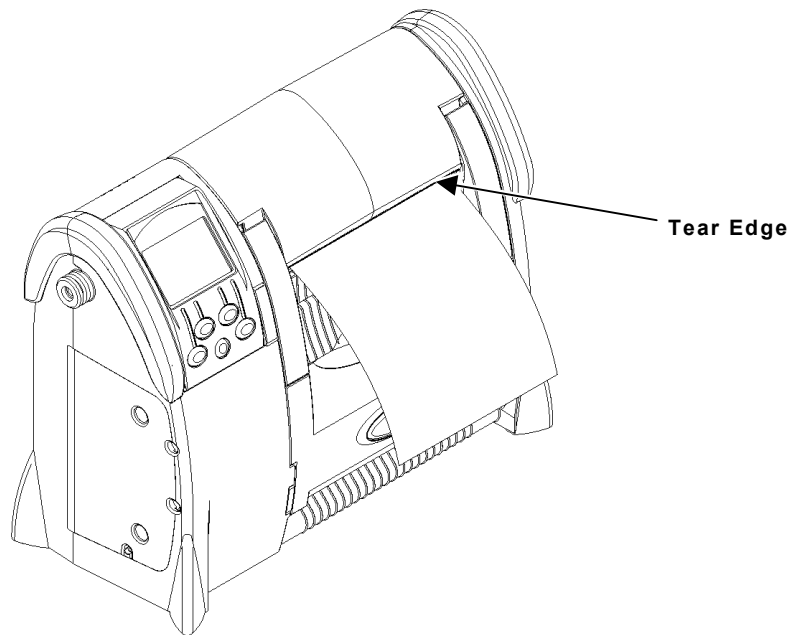

Note: Do not pull straight up on the supply. You may lose registration.

This chapter explains how to

- ◆ clear label jams.
- ◆ clean the printhead, platen roller, and supply sensors.

Caution: **Do not** use sharp objects to clean the printhead or touch the printhead with your fingers. This may damage the printhead and require a service charge.

Clearing Label Jams

When you are printing and a jam occurs, a supply error message appears. To clear the jam:

1. Turn off the printer by pressing Ⓞ.
2. Open the printer and remove the supply roll.
3. Use your fingers to remove the jammed supplies. **Do not** use sharp objects to remove jammed supplies. This may damage the printer.
4. Clean the printhead and platen roller to remove any adhesive. See “Cleaning” for more information.
5. Reload supplies and close the printer.
6. Turn on the printer by pressing Ⓞ.

Cleaning

Your printing rate and frequency determines how often you must clean the printer.

You may need to clean the printhead and platen roller

- ◆ after using seven to ten (7-10) rolls of supplies.
- ◆ when you replace the ribbon.
- ◆ in extreme temperatures, humid conditions or a dirty environment.
- ◆ when you see voids in the print.
- ◆ after a label jam.



Voids in print

You may have to clean the supply sensors more often if you receive supply error messages frequently.

Use any of the following items to clean the printhead:

- ◆ A clean, soft cloth.
- ◆ A cotton swab moistened with isopropyl alcohol.

Caution: Use isopropyl alcohol on the interior areas only, never on the exterior. **Do not** use household cleaners to clean the printer.

- ◆ A Cleaning Pen (order part number 114226).

To clean the printhead, platen roller, and supply sensors:

1. Ground yourself by touching a metal surface before cleaning the printer. Grounding prevents electrostatic discharge, which may damage the printhead.
2. Turn off the printer.
3. Open the printer and remove the ribbon cassette and any supplies.

Note: **Do not** use sharp objects to remove adhesive or label particles from the printer.

4. Clean the printhead with a clean soft cloth, a cotton swab moistened with isopropyl alcohol, or a cleaning pen.

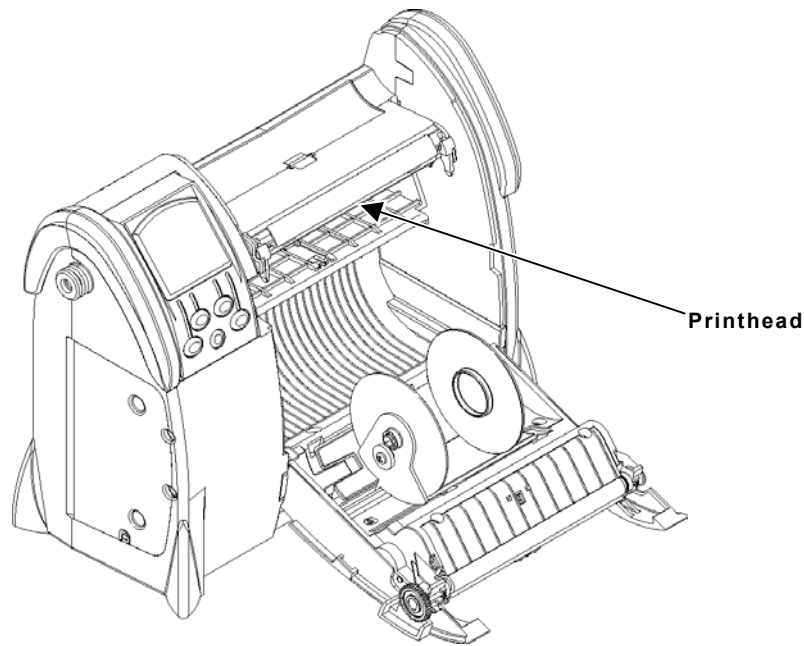

5. Clean the platen roller with a clean soft cloth moistened with isopropyl alcohol or a cleaning pen. Turn the platen roller with your finger to clean the entire surface.
6. Clean the on-demand and black mark sensors with a clean soft cloth, a cotton swab moistened with isopropyl alcohol, or a cleaning pen.

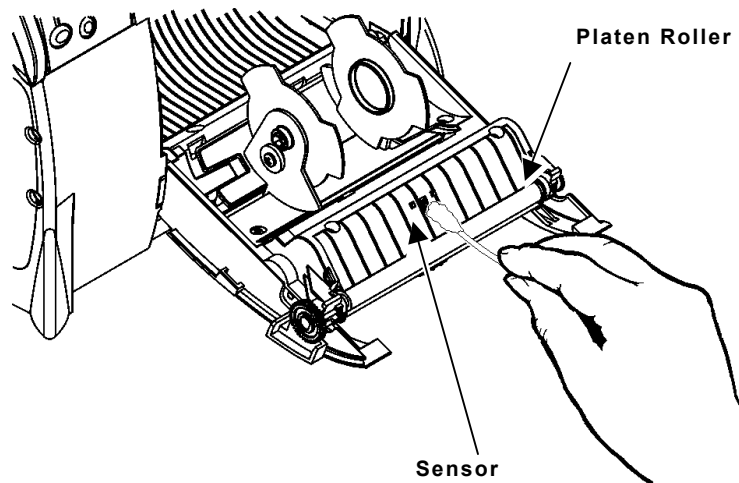

7. Allow the printer to dry.
8. Reload the ribbon cassette and the supply.
9. Close the printer.
10. Turn on the printer and press **↑** to advance the supply.

TROUBLESHOOTING

4

This chapter lists some common problems and their solutions.

Problem	Solution
Printer does not feed.	Use a fully charged battery. Close the printer completely. Load the supply and ribbon correctly. Run the printer diagnostic tests. Refer to the <i>System Administrator's Guide</i> for more information.
Printer does not print.	Use a fully charged battery. Close the printer completely. Clean the printhead. Run the printhead diagnostics tests. Refer to the <i>System Administrator's Guide</i> for more information.
Print has voids or is too light.	Use a fully charged battery. Close the printer completely. Load the supply and ribbon correctly. Clean the printhead. Run the printhead diagnostics tests. Refer to the <i>System Administrator's Guide</i> for more information.
Printer turns off while printing and/or the display goes blank.	Use a fully charged battery. Resend the format. The maximum black to white print ratio for each label/tag is 30%. Check your format for unnecessary, thick horizontal lines.

Common Errors

The following is a list of common printer errors you may receive. If you receive a message not listed here, see your System Administrator or call Service.

Error	Description
025 Invalid Length	String length is outside the range 0 to 2710 .
101 Invalid/Missing	The format referenced by batch is not in memory.
409 Memory Full	The printer memory is full. Delete unnecessary formats or graphics from memory.
410 Parity	Parity mismatch. Check your parity settings at the printer and at the host.
411 Framing	Framing error (baud rate mismatch). Check your baud rate settings at the printer and at the host.
413 Overrun	Online receive queue is full. Check for a flow control problem.
611 Error Loading	Font, bar code, or density in the batch does not fit the format.
612 Invalid Data	The data in this line of the batch is missing or does not match the format.

Error	Description
613 Invalid Data	Reference point off supply.
614 Invalid Data	Portion of field off supply or there may be an invalid character in the packet.
703 Check Supply	The printer sensed a calibration of different-sized black marks. Make sure the correct supply is loaded.
704 Check Supply	Printer has not sensed a supply mark within the specified number of inches or is out of supplies. Check the supply tracking, supply marks, black mark sensor position, and supply roll for binding. Press X to clear the error. Change supply.
750 Hot Head	Printhead is overheated. Press X to clear the error. Turn off the printer to let the printhead cool. If error persists, call Service.
751 Check Supply	Printer did not sense a black mark when expected. For errors 751-753, Check the supply tracking, supply marks, black mark sensor position, and supply roll for binding. Press X to clear the error and try to continue printing the batch. Change supply.
752 Check Supply	Printer sensed a mark in the wrong place. Press X to clear the error.
753 Check Supply	Printer sensed a mark that is too long. Press X to clear the error.
756 Load Supplies	Load supplies. Press X to clear the error.
757 Load Supplies	Load supplies (supply length mismatch), because the calibrated supply length differs by plus or minus 0.25 inches from the format. Press X to clear the error.
758 Check Supply	Either the supply is not seen or the on-demand sensor is broken. Press X to clear the error. Check for a label jam, clear the supply path, or reload supplies. This error may occur if you remove a label too quickly in on-demand mode. The printer does not recalibrate after this error.
762 Low Battery	Recharge the battery. Press X to clear the error.
763 Remove Label	Waiting to dispense label. Press X to clear the error.
765 Check Printhead	The printhead has less than four bad dots. The printer can shift bar code fields to avoid bad dots. Press X to clear the error and continue printing.
768 Check Printhead	Printhead has more than 10 bad dots or is not connected. Connect the printhead. Press X to clear the error.
791 Error Pending	The printer has an error pending. Turn off the printer. Wait 15 seconds and turn it back on. Resend the packets.

Calling Technical Support

If these solutions do not work, or you see an error that is not listed here, call Service at the number listed on the back of this manual.

If you need to return the printer, use the original packaging (box and packing material).

SPECIFICATIONS



Printer Specifications

Height:	8.0" (203 mm)
Width:	10.1" (254 mm)
Depth:	4.6" (117 mm)
Weight with Battery:	4.7 lbs. (2.14 kg)
Display:	Graphical 4-line LCD with backlight
Printhead:	4" (102 mm) 203 dpi (8 dots per mm)
Memory:	32MB RAM 32MB Flash 256MB microSD card (option)
Power:	14.8V Lithium-Ion battery
Battery Life:	10,000" (254 m) of 25% black supplies
Operating Limits:	32° to 104°F (0° to 40°C)
Storage Limits:	-4° to 122°F (-20° to 50°C)
Relative Humidity:	5% to 90% non-condensing
Printing Method:	Thermal direct & thermal transfer
Recommended Duty Cycle:	33% Duty Cycle (5 minutes out of 15 minutes time intervals). On-demand or intermittent printing has no restrictions.

Supply Specifications

Supply Types:	Thermal direct and thermal transfer labels, tags, fan-fold, or receipt paper.
Supply Widths:	2.0" (51 mm) minimum Label with Liner Maximum: 4.65" (118 mm) Thermal Direct 4.10" (104 mm) Thermal Transfer Tag/Receipt Paper Maximum: 4.0" (102 mm)
Supply Lengths:	12.0" (305 mm) maximum
Maximum Print Area:	4.0" (102 mm) x 12.0" (305 mm)

ACCESSORIES

B

Use these part numbers when ordering an item.

Call us at the number listed on the back of this manual to order parts or supplies.

Part Number	Item
M09496	Battery Charger/AC Power Adapter
127201	Spare Battery
12665914	Communication Cable - DB9 to 9-pin
12029315	Communication Cable - DB9 to 25-pin
125859	USB Cable - Type A to Mini-B
127219 (core) 127287 (guides)	4-inch (102 mm) Core & Flanges/Guides (must order both parts for a complete fan-fold core)
12813420	10-pack of 2-inch (51mm) ribbons
12813430	10-pack of 3-inch (76 mm) ribbons
12813440	10-pack of 4-inch (102 mm) ribbons
127205	Ribbon Cassette (no ribbon)
127571	Shoulder Strap
127570	Hand Strap
11997208	Cleaning Pen
TC9493QR	<i>Quick Reference</i>
TC9493MLIQR	<i>MLI Quick Reference</i>
TC9493PR	<i>Packet Reference</i>
TC9493SA	<i>System Administrator's Guide</i>
TC9460SNPSA	<i>Network System Administrator's Guide</i>

Battery Charger/AC Power Adapter

The Monarch® 9496™ Battery Charger/AC Power Adapter is designed for the Monarch® 9493™ portable printer. It charges the battery and provides alternative AC power. For more information about the battery, see Chapter 1, "Getting Started." For more information about the charger/adapter, refer to the 9496™ *Operating Instructions* (TC9496OI) included with the charger/adapter.

Carrying Accessories

Shoulder and hand straps are available for carrying your portable printer. Refer to the *Strap Instructions* (TC9460ACPHOI) provided with your strap for more information.

PRINTER OPTIONS



This appendix lists the options that may be installed in your printer.

- ◆ Bluetooth®

Bluetooth®

Bluetooth wireless technology provides a low power-consuming method to communicate between devices. It has a maximum range of 30 feet (10m).

Our Bluetooth device connects to your printer's serial port and conforms to V2.0 of the Bluetooth specification. The printer defaults to receiving unencrypted data for the Bluetooth device. See the *System Administrator's Guide* for more information about Bluetooth.



Avery Dennison Printer Systems Division
170 Monarch Lane
Miamisburg, OH 45342

1-800-543-6650 (In the U.S.A.)
1-800-387-4740 (In Canada)
www.monarch.com